

國際藝術考試評審中心
International Arts Examination Board

www.iaebart.org

IAEB Introduction



International Arts Examination Board (IAEB) is a globally recognized organization, dedicates on evaluating and celebrating the outstanding artistic and musical talents. It provides its platform to students with the passion of music and art, to showcase their abilities and gain widespread recognition.

“開啟藝術潛能，擁抱創造力”

"Unlock Your Artistic Potential, Embrace Creativity"



International recognition

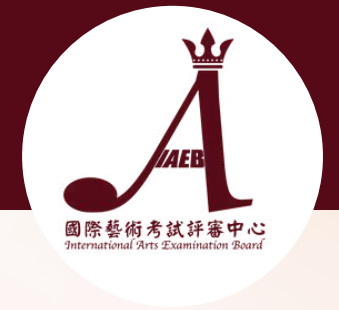

The International Arts Examination Board's exams deliver Ofqual regulated certificates when passed and deliver internationally recognised UK & EU credits.

The Office of Qualifications and Examinations Regulation (Ofqual) regulates qualifications, examinations and assessments in the UK.

Ofqual website:

<https://www.gov.uk/government/organisations/ofqual>

Art Painting Exam Online Exam Assessment



Integrated Drawing



Watercolour Drawing



Acrylic Painting



Sketching



Comic



Oil Painting

Exam Level



Subject	Integrated Drawing	Watercolour Drawing	Acrylic Painting	Sketching	Oil Painting	Comic
Elementary	Foundation					
	Level 1	Level 1	Level 1	Level 1	Level 1	Level 1
	Level 2	Level 2	Level 2	Level 2	Level 2	Level 2
Intermediate	Level 3	Level 3	Level 3	Level 3	Level 3	Level 3
	Level 1	Level 1	Level 1	Level 1	Level 1	Level 1
	Level 2	Level 2	Level 2	Level 2	Level 2	Level 2
Higher	Level 3	Level 3	Level 3	Level 3	Level 3	Level 3
	Level 1	Level 1	Level 1	Level 1	Level 1	Level 1
	Level 2	Level 2	Level 2	Level 2	Level 2	Level 2
	Level 3	Level 3	Level 3	Level 3	Level 3	Level 3
	Total	Total	Total	Total	Total	Total
	10 Levels	9 Levels	9 Levels	9 Levels	9 Levels	9 Levels

Exam Scoring Criteria

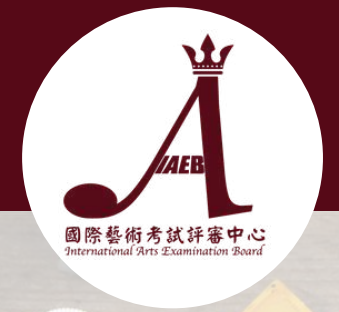

Grading Criteria	Highest Score
Composition	25
Creativity	25
Skill	25
Completeness	25
Total score	100

Score Category	Score Range
Distinction	80 or above
Merit	66 - 79
Fair	50 - 65
Ungraded	49 or below

Graded Fine Arts Exam

Candidate : _____
Presented by : _____
Subject : _____ Grade: _____

國際藝術考試評審中心
International Arts Examination Board

	Marks
Composition	/25
Creativity	/25
Skill	/25
Completion	/25
Additional Comments (if needed).	/25
Total:	/100

Distinction 80-100
Merit 66-79
Good 50-65
Ungraded 49 or below

Examiner code: P.Mak

This form records the result of an exam held on : _____
International Arts Examination Board
Website: www.iaeb.org
Email: exam@iaeb.org

20231221/wh/v3

Elementary Exam assessment Syllabus - Integrated Drawing

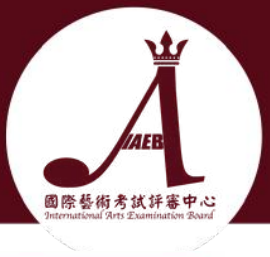

Subjects	Grade	Topic	Exam Requirements	Tools	Grading Criteria	For a limited time
Integrated Drawing	*Foundation (2 years old up)	Colouring Fruits/Geometry /Pets/Insects	Know how to distinguish colours and apply colours within a specified range of black and white images.	Wood color, pen, crayons (A4, A3 paper optional)	Can fill in the pattern and color it evenly, and I distinguish the color correctly.	90 minutes
	*Level 1 (3 years old up)	My favourite toy/food	Within the specified range of images of black and white toys or food, and painted with colour. Create a background or draw other patterns in the blank space outside the image and fill in the colour.	You can add an appropriate amount of handicraft materials freely: Rags, colored shredded paper, film, plastic beads, beans and environmentally friendly materials, etc.	Can fill in the pattern without going out of bounds, evenly coloring, and distinguish the color correctly. With handicrafts and ecofriendly materials, you can freely create the patterns and backgrounds of the paintings to match the theme.	90 minutes
	*Level 2 (5 years old up)	My favourite animal/fruit	Within the specified range of images of black and white animals/fruits, colour is painted. Create a background or paint other patterns in the blank space outside the image, using different pigments and rich colours, and using simple lines to draw the shapes and forms of different animals and fruits.	Tool: Paste, glue, small broom, scissors. Small fans and hair dryers can be used to dry paintings.	Able to use different pigments and environmentally friendly materials, paint paintings, express rich colors, be creative, and the background can match the theme.	90 minutes
	*Level 3 (7 years old up)	My favourite cartoon characters/world famous buildings	Using different pigments and rich colours, you can draw the shape and form of different cartoon characters or world famous buildings, and draw a complete theme.	You can use pencil and eraser to draw sketches.	Able to use different pigments and environmentally friendly materials to make paintings, with high realism, threedimensional expression, highlighting creative thinking, and the background can match the theme.	90 minutes

* You can download the coloring exam from the official website www.iaebart.org

Integrated Drawing Elementary Exam - Foundation (Fruit) Coloring Exam Paper

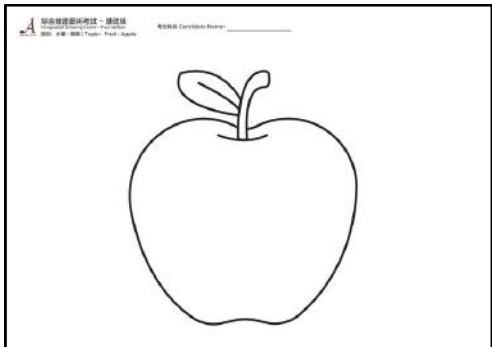
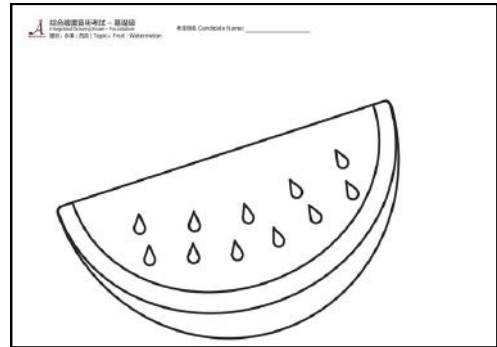
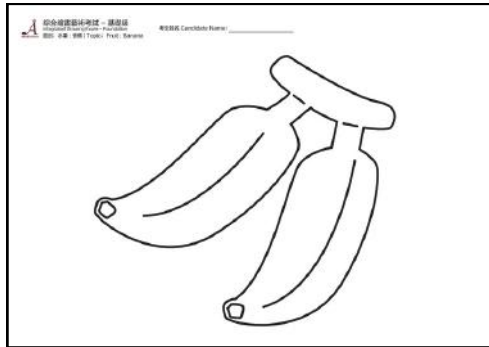
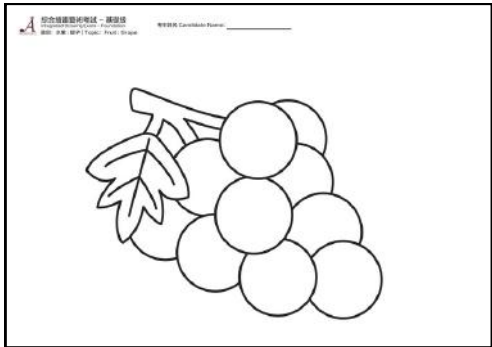
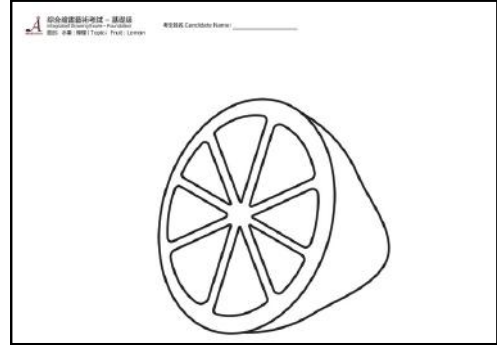
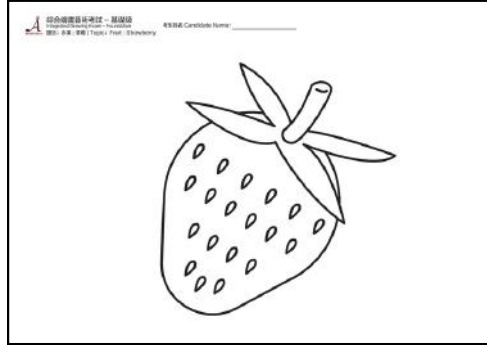
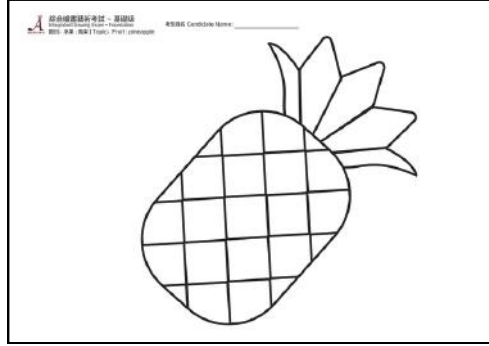
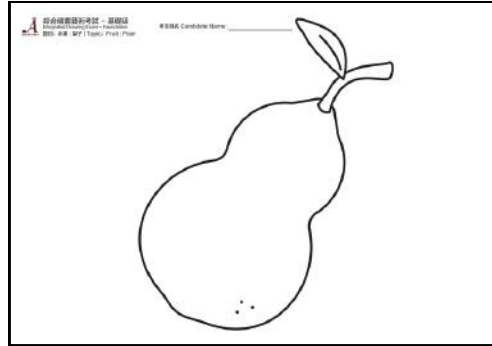

*Please pay attention to the examination requirements and scoring criteria at each level.

Integrated Drawing Elementary Exam - Foundation (Geometry) Coloring Exam Paper

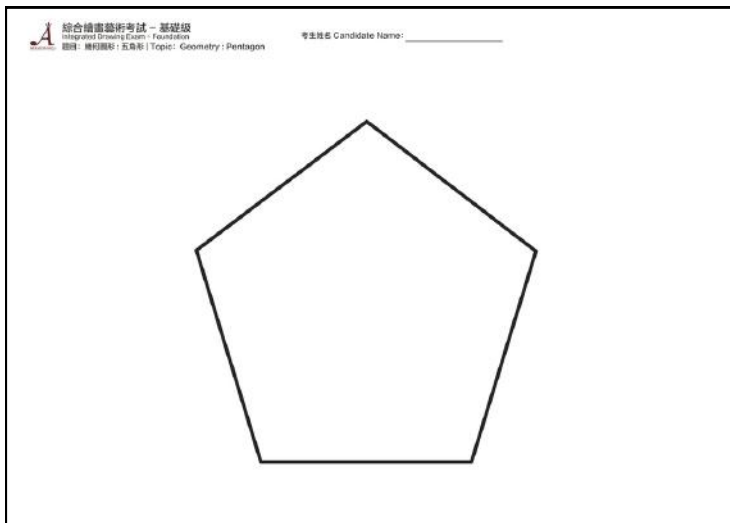
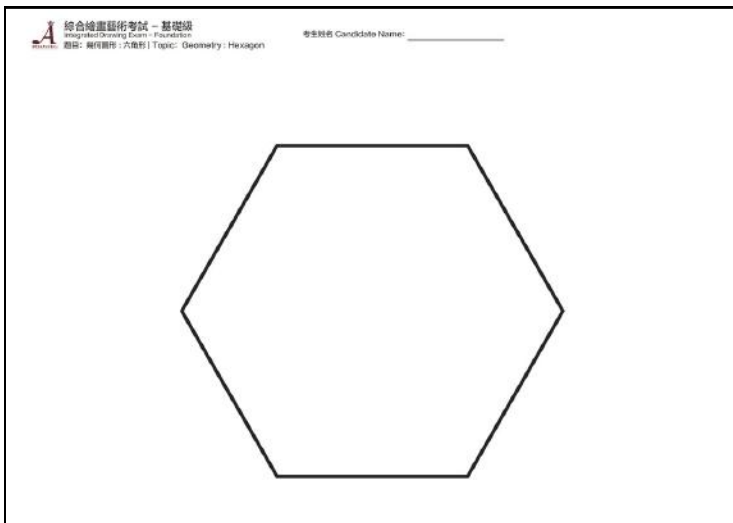
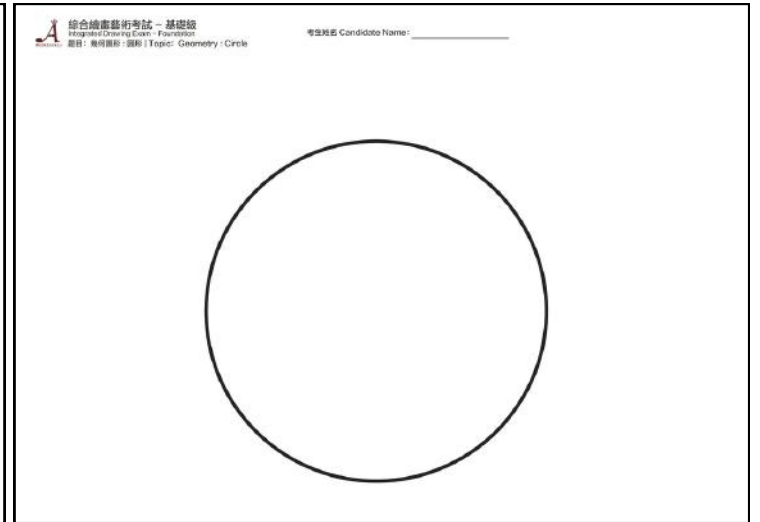
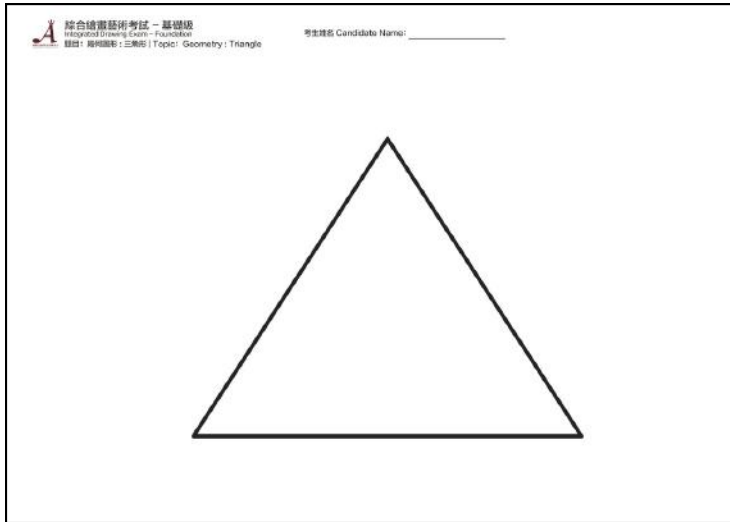
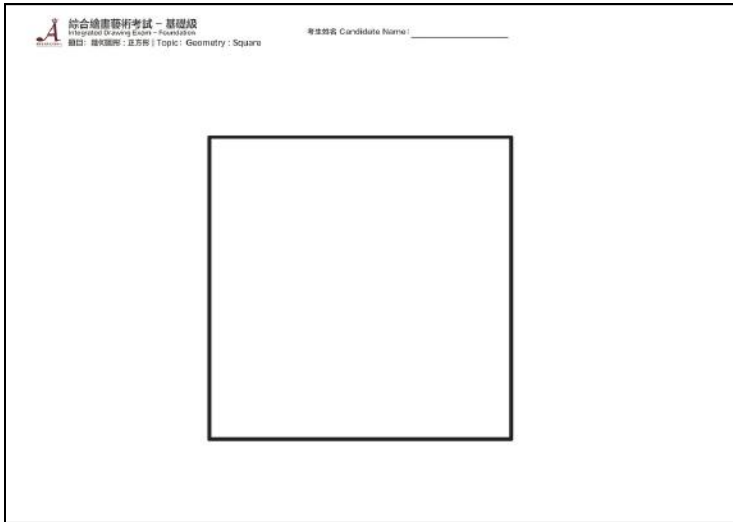

*Please pay attention to the examination requirements and scoring criteria at each level.

Integrated Drawing Elementary Exam - Foundation (Pet) Coloring Exam Paper

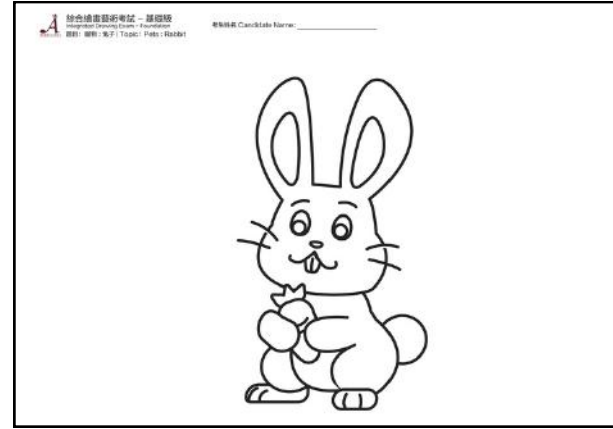
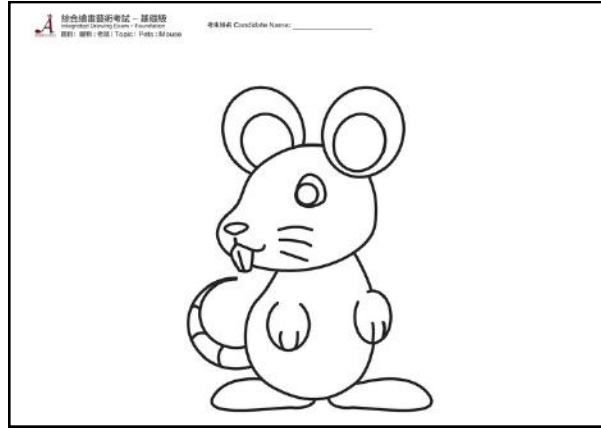
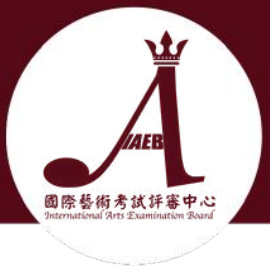

*Please pay attention to the examination requirements and scoring criteria at each level.

Integrated Drawing Elementary Exam - Foundation (Insect) Coloring Exam Paper

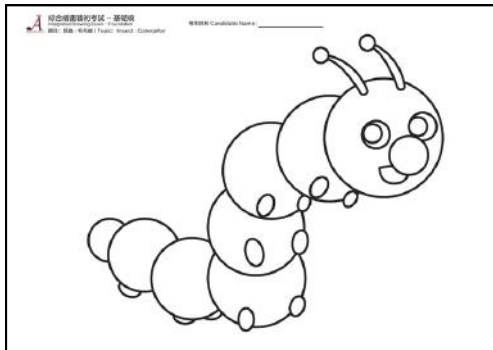
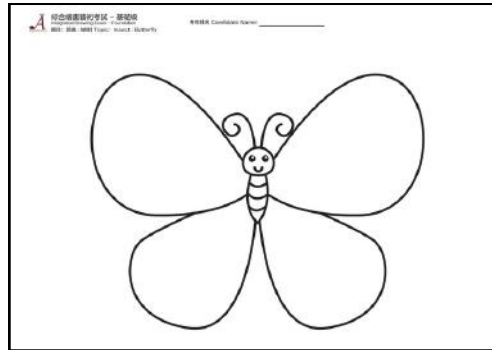
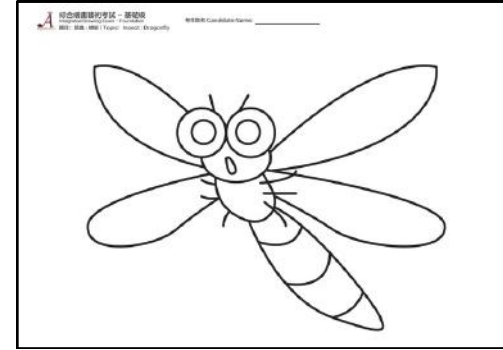
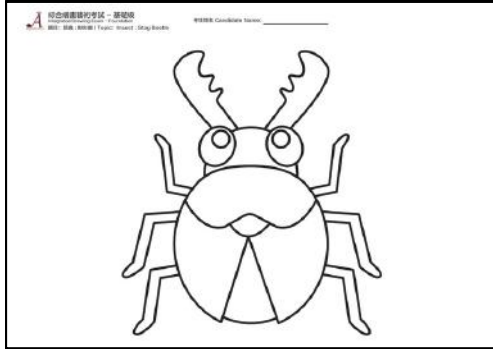

*Please pay attention to the examination requirements and scoring criteria at each level.

Integrated Drawing Elementary Exam - Level 1 (Toy) Coloring Exam Paper

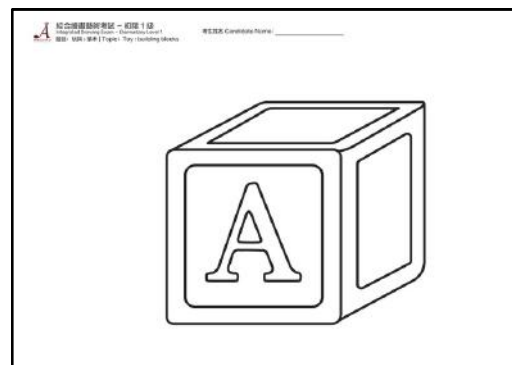
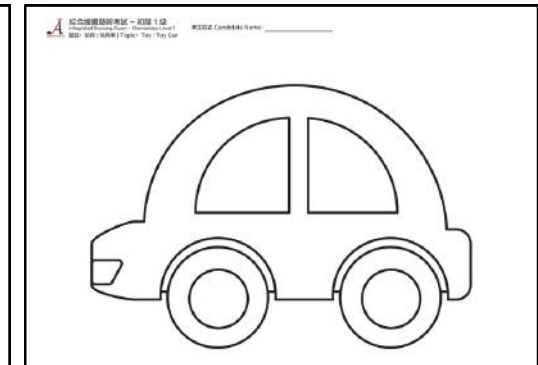
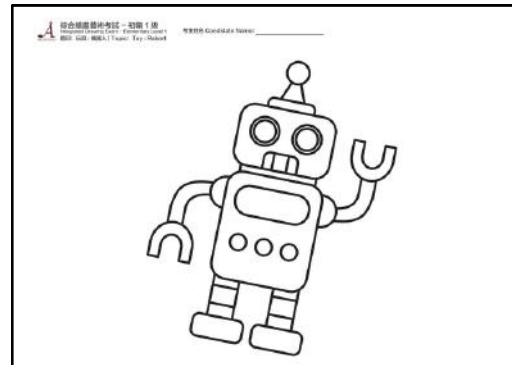
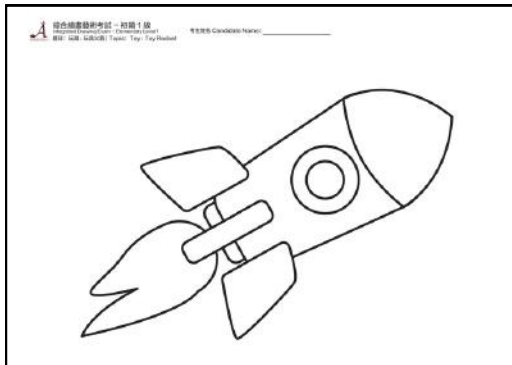
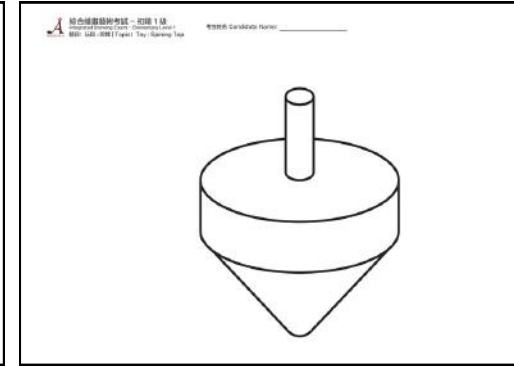
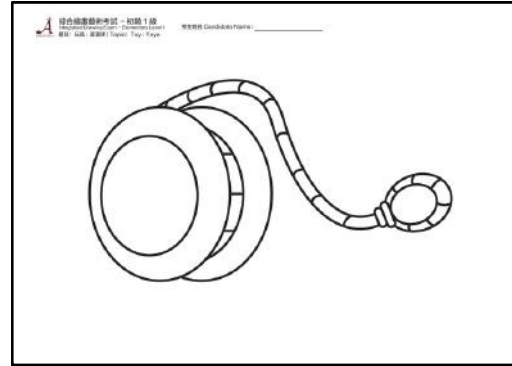
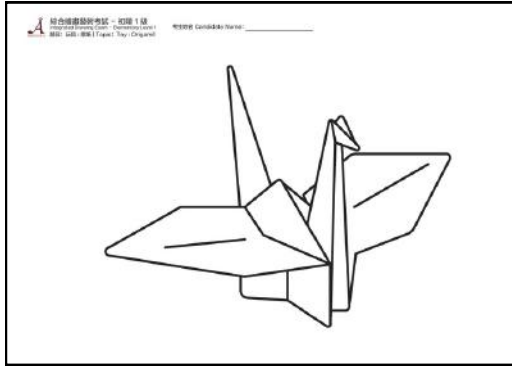

*Please pay attention to the examination requirements and scoring criteria at each level.

Integrated Drawing Elementary Exam - Level 1 (Food) Coloring Exam Paper

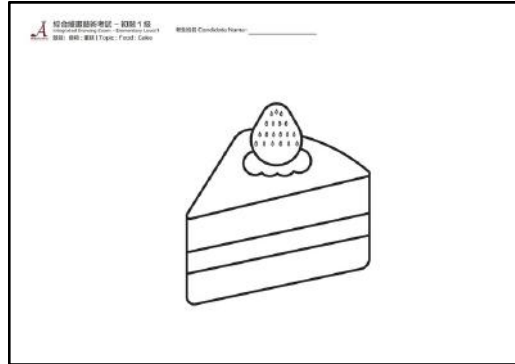
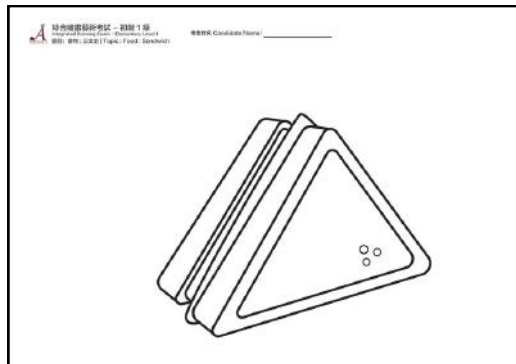
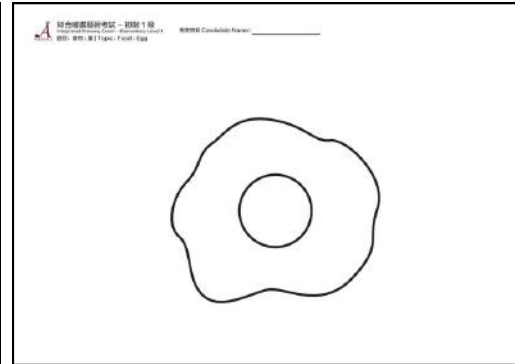
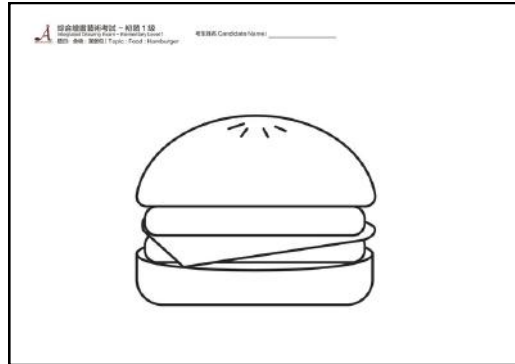
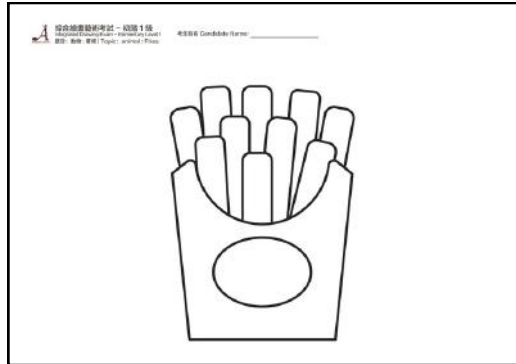
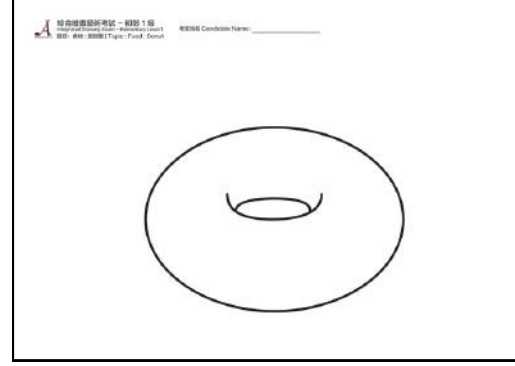
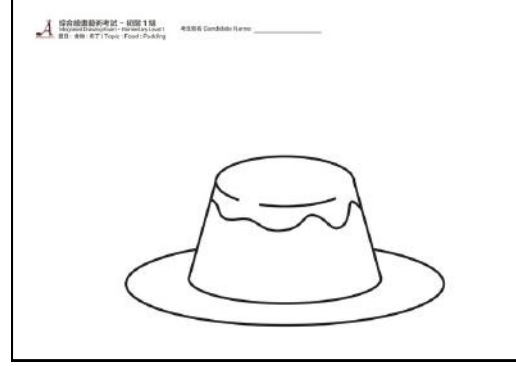
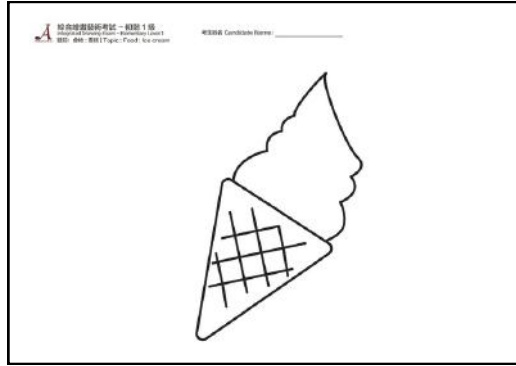
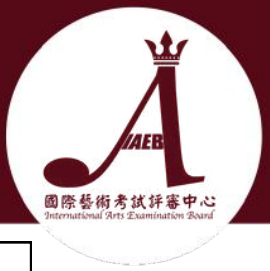

*Please pay attention to the examination requirements and scoring criteria at each level.

Integrated Drawing Elementary Exam - Level 2 (Animal) Coloring Exam Paper

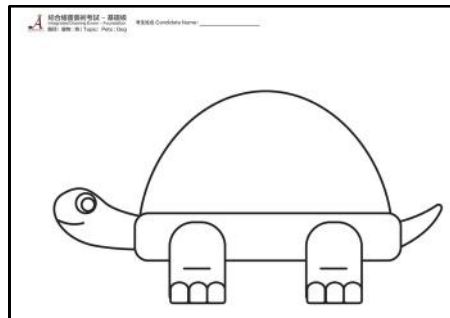
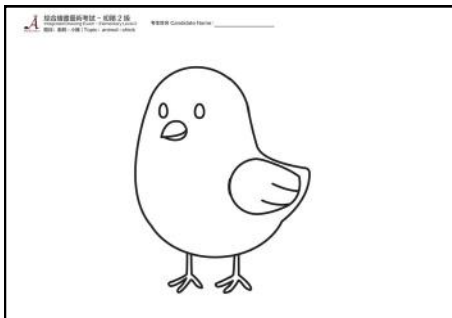
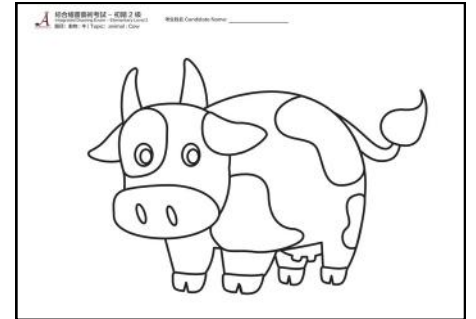

*Please pay attention to the examination requirements and scoring criteria at each level.

Integrated Drawing Elementary Exam - Level 2 (Fruit) Coloring Exam Paper

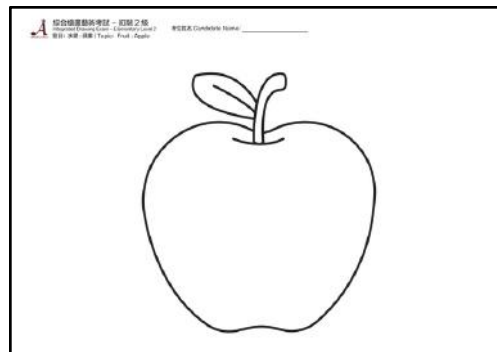
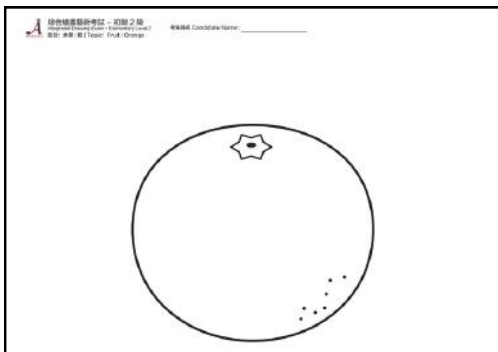
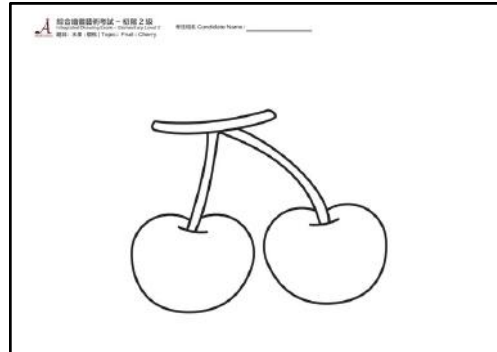
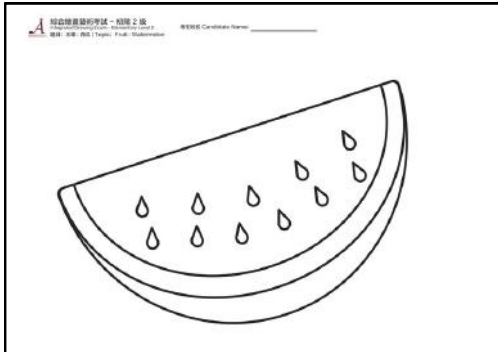
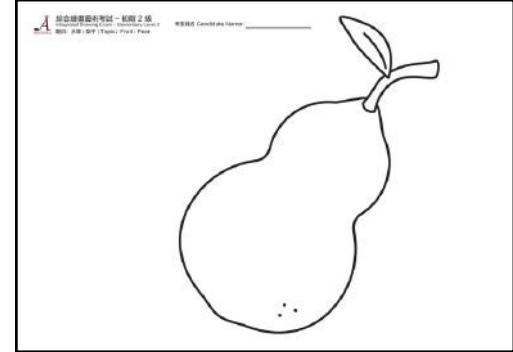
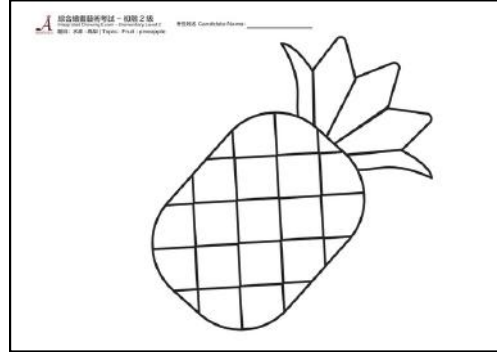
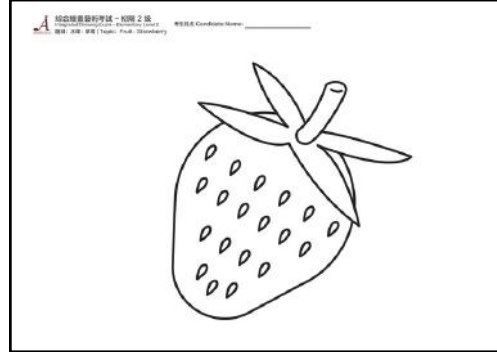
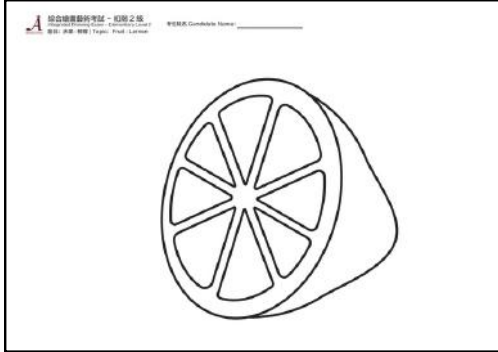

*Please pay attention to the examination requirements and scoring criteria at each level.

Elementary Exam Assessment Syllabus Integrated Drawing



Remark :

1. Candidates who apply for the basic level/level one/level two of comprehensive painting can accept the instructor to be beside the candidate and guide the candidate orally through the entire examination assessment process so as to complete the painting on time;
2. However, instructors are not allowed to assist candidates in completing the entire exam assessment painting;
3. Instructors are not allowed to be at the exam site, videotaping or recording;
4. The instructor does not need to wear a mask at the examination site and needs to be able to see his face;
5. The instructor must be over 18 years old or above, and can be a teacher/parent/guardian, etc.;
6. The coverage of handicraft materials can only be accepted within 50% of the entire drawing paper;
7. The Comprehensive Drawing Examination is an assessment that encourages children to take part starting from the age of two, with the aim of cultivating their creativity and thinking abilities from an early age.

See photos of artwork by 4-5 year olds to the right



Elementary Exam Assessment Syllabus – Watercolor Painting

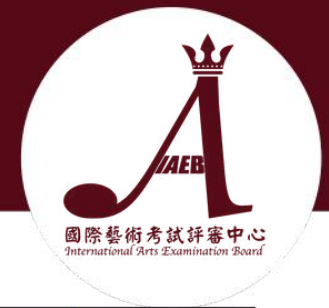

Subjects	Grade		Topic	Exam Requirements	Tool	Grading	For a limited time
Watercolour Painting	Elementary	Level 1	My favourite fruit	A single piece of fruit. Use basic watercolor techniques to show the principles of color such as warm and cold colors, adjacent colors, and contrasting colors.	Watercolor paint, watercolor box, brush, (A4, A3 and A2 watercolor paper optional) Small fans and hair dryers can be used to dry paintings. You can use pencil and eraser to draw sketches.	Understand the performance of watercolor and have basic color grading ability.	90 minutes
		Level 2	My favourite insects	A single insect. Use basic watercolor techniques to show the principles of color such as warm and cold colors, adjacent colors, and contrasting colors.		It has the ability to mix basic colors, the composition is biased to be complete, and it can express the basic cold and warm effects.	
		Level 3	My favourite toys/pets	Single toy/pet. Use basic watercolor techniques to express color principles such as warm and cold colors, adjacent colors, and contrasting colors.		The composition is nearly complete and the color contrast is strong.	

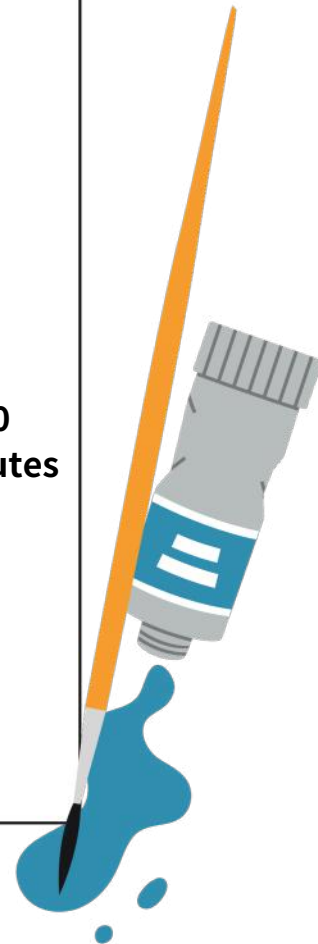

Elementary Exam Assessment Syllabus – Acrylic Painting



Subjects	Grade	Topic	Exam Requirements	Tool	Grading Criteria	For a limited time
Acrylic Painting	Elementary	Level 1 Fruit	The painting is a simple still life, and the theme is simple, and the background is coordinated.	Acrylic Paints, drawing boards, canvases, Acrylic brushes, (A4, A3, A2 paper optional) Small fans and hair dryers can be used to dry paintings. You can use pencil and eraser to draw sketches	The proportions of the composition are relatively complete, and the initial use of color to depict the object, express the hue, warmth and coldness, and the sense of light.	90 minutes
		Level 2 Fruits and utensils	Depict a simple basket of fruits, at least 2 fruits and a utensil.		The technical foundation and the accuracy of the modeling, the theme must be clear and the background is coordinated, the color and the stereoscopic vision.	
		Level 3 Vegetables and fruits and utensils	A simple basket of vegetables, at least 2 fruits and utensils is depicted. Backgrounds are free to create.		The proportion of the composition arrangement is relatively complete, and the color can be better used to depict the object, the color block contrast is clear, the hue, cold and warm and light sensation can be expressed, and a certain tone can be formed, and a certain three-dimensional visual effect can be made.	



Elementary Exam Assessment Syllabus – Sketching



Subjects	Grade	Topic	Exam Requirements	Tool	Grading Criteria	For a limited time
Sketching	Elementary	Level 1	Gypsum geometry Depict 1 plaster geometry. Through light and shadow, line and brushwork, and depth, simple objects are drawn.	Black pencil (B-6B), eraser (Plastic rubber or 4B rubber), (A4, A3, A2 paper optional)	The composition is appropriate, and the proportions of the shape are moderate and clear.	90 minutes
		Level 2	Gypsum geometry Depict 2 plaster geometries. Through light and shadow, line and brushwork, and depth, simple objects are drawn.		The composition is appropriately proportioned, the form is accurate, and there is a simple and distinct relationship between light and dark.	
		Level 3	Gypsum geometry Depict 3 plaster geometries with a tablecloth or tabletop. Through light and shadow, line and brushwork, and depth, simple objects are drawn.		Expresses a three-dimensional sense of appropriate proportions, changes in texture and tone.	

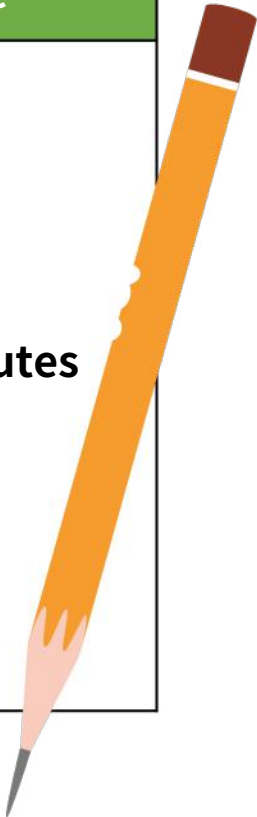

Elementary Exam Assessment Syllabus – Oil Painting



Subjects	Grade	Topic	Exam Requirements	Tool	Grading Criteria	For a limited time
Oil Painting	Elementary	Level 1 Fruit	Paint a fruit and create freely with content.	Oil paints, pads, brushes, (A4, A3, A2 canvases optional) Small fans and hair dryers can be used to dry paintings. You can use pencil and eraser to draw sketches.	The composition is generally appropriate, and the objects can be depicted using color, and the color contrast is clear.	90 minutes
		Level 2 Still Life	Paint a still life and create freely with content.		The composition arrangement is close to complete, and it can express the warmth and coldness of the colors and the feeling of light, and the color contrast is clear.	
		Level 3 Scenery	Paint a scenery and create freely with content.		The proportions of the composition are roughly complete, and the warmth and warmth of the colors and the sense of light can be expressed, and the color contrast is clear.	

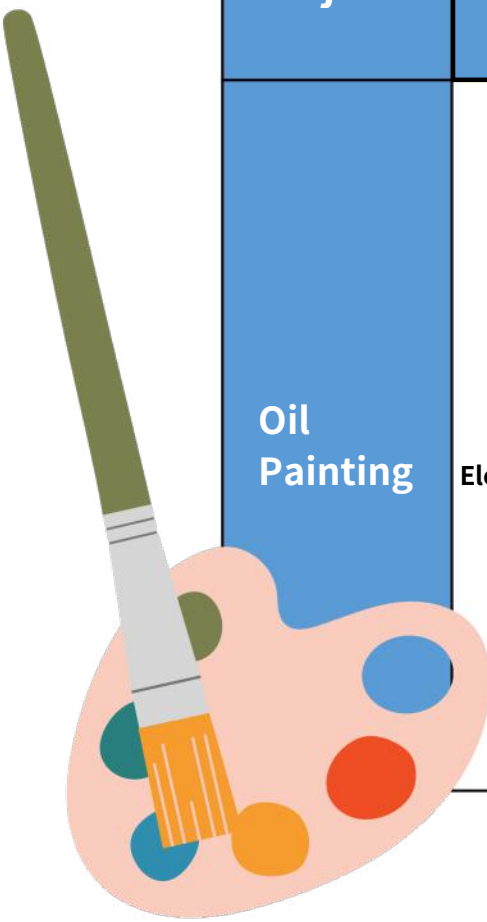

Elementary Exam Assessment Syllabus – Comic

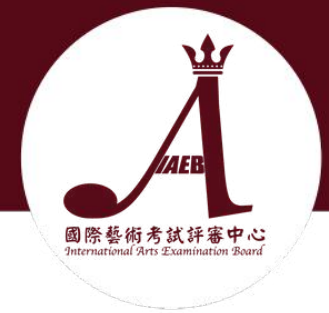

Subjects	Grad		Topic	Exam Requirements	Too	Grading Criteria	For a limited time
Comic	Elementary	Level 1	Cartoon characters/Comic characters (one person)	Lines are used to depict basic manga characters and things	Marker (pen), pencil, wood color, Acrylic, (A2, A3, A4 paper optional)	Able to grasp the depiction of the basic shape.	90 minutes
		Level 2	Cartoon characters/Comic characters (two persons)	Use lines to depict the characteristics of basic comic characters or things, such as age, dynamics, expressions, gender, height, fatness, personality, etc		Able to grasp the average proportions of the depicted form and smooth lines.	
		Level 3	Cartoon characters/Comic characters (more persons)	Use lines to depict the characteristics of more than 2 basic comic characters or things, such as age, dynamics, expressions, gender, height, fatness, personality, etc.		Able to grasp the depiction of basic shapes, and have simple body language such as movement, expressions, and facial features.	

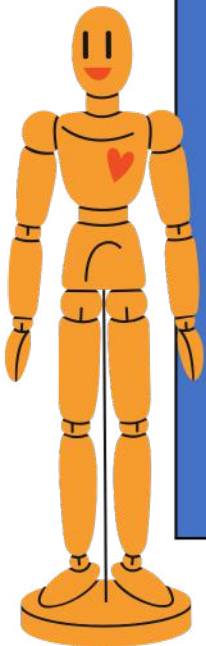

Exam Assessment Syllabus–Intermediate

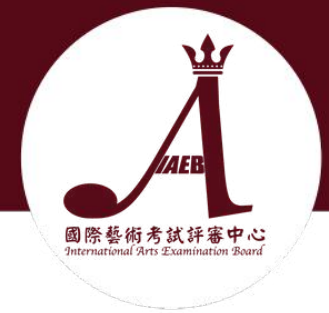

Grade	Topic	Exam Requirements	Grading Criteria	For a limited time
Intermediate	Level 1 1. My life 2. Festival 3. Athletic competitions 4. Environmental Protection 5. My home	Choose one of the topics as the theme, with appropriate background, and ask for a 50-100 word creative description of the work.	<ul style="list-style-type: none"> • Composition: Near-complete. The styling is accurate and concrete • Skills: It can better express the morphological structure of people or objects, and the color is warm and cold, the sense of space, the texture and the sense of three-dimensionality. • Creativity: Creative ability, imagination • Complete: Ability to complete drawings within a time frame. 	120 minutes
	Level 2 6. Sharing 7. Sightseeing 8. My hobbies 9. My favorite animal 10. My favorite pet 11. The person I respect the most 12. My favorite food 13. My dream	Choose 2 of the topics as the theme, with appropriate background, and ask for a 50-100 word creative description of the work.	<ul style="list-style-type: none"> • Composition: Near-complete. Styling correctly • Skills: Know how to use color to express the unique layering, three-dimensionality and spatial sense of the body's movements and expressions/objects and styles. • Creativity: Creative ability, imagination • Complete: Ability to complete drawings within a time frame. 	
	Level 3 14. Season: Spring/Summer/Autumn/Winter 15. The great person of the world 16. The future of AI world	Choose 3 topics as the theme, with appropriate background, and ask for a 50-100 word creative description of the work.	<ul style="list-style-type: none"> • Composition: Near-complete. Accurate modeling • Skills: The layers are clear, the content is rich and vivid, the color contrast is clear, the cold and warm are distinct, the characters are similar, the expressions are natural, the facial features are evenly proportioned, and there is a sense of three-dimensional and space. • Creativity: Rich imagination and the ability to write stories • Complete: Ability to complete drawings within a time frame. 	

Exam Assessment Syllabus – Intermediate



Please select one of the following materials/tools from 1 to 6 for drawing:

- 1. Integrated Drawing :** wood color, pen, crayons, (A4, A3 drawing paper optional). You can freely add handicraft materials in an appropriate amount: rags, colored shredded paper, film, plastic beads, beans and environmentally friendly materials. Tools: paste, glue, small broom, scissors.
- 2. Watercolor:** watercolor paint, watercolor box, brush, (A4, A3 and A2 watercolor paper optional).
- 3. Sketching:** black pencil, charcoal, charcoal strip, charcoal, eraser, (A4, A3, A2 drawing paper optional).
- 4. Oil painting:** oil paints, drawing boards, oil brushes, (A4, A3, A2 canvases optional).
- 5. Acrylic Painting:** Acrylic paint, drawing board, canvas, Acrylic brush, (A4, A3, A2 paper optional).
- 6. Comic :** Marker (pen), pencil, wood color, Acrylic, (A2, A3, A4 paper optional).
- 7. Small fans and hair dryers can be used to dry paintings.**
- 8. You can use pencil and eraser to draw sketches.**

Exam Assessment Syllabus – Higher

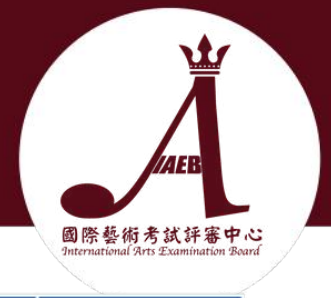

Grade	Topic	Exam Requirement	Grading Criteria	For a limited time
Higher	Level 1	<p>S Choose one of the topics as the theme, with appropriate background, and ask for a 50-100 word creative description of the work.</p>	<ul style="list-style-type: none"> • Composition: Near-complete. The styling is accurate and concrete • Skills: It can better express the morphological structure of people or objects, and the color is warm and cold, the sense of space, the texture and the sense of three-dimensionality. • Creativity: Creative ability, imagination • Complete: Ability to complete drawings within a time frame. 	150 minutes
	Level 2	<p>Choose 2 of the topics as the theme, with appropriate background, and ask for a 50-100 word creative description of the work.</p>	<ul style="list-style-type: none"> • Composition: Near-complete. Styling correctly • Skills: Know how to use color to express the unique layering, three-dimensionality and spatial sense of the body's movements and expressions/objects and styles. • Creativity: Creative ability, imagination • Complete: Ability to complete drawings within a time frame. 	
	Level 3	<p>Choose 3 topics as the theme, with appropriate background, and ask for a 50-100 word creative description of the work.</p>	<ul style="list-style-type: none"> • Composition: Near-complete. Accurate modeling • Skills: The layers are clear, the content is rich and vivid, the color contrast is clear, the cold and warm are distinct, the characters are similar, the expressions are natural, the facial features are evenly proportioned, and there is a sense of three-dimensional and space. • Creativity: Rich imagination and the ability to write stories • Complete: Ability to complete drawings within a time frame. 	

Exam Assessment Syllabus – Higher

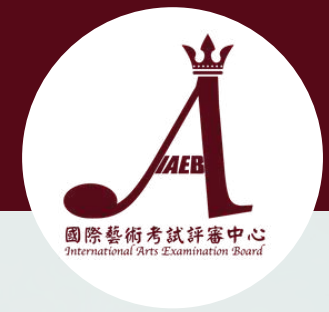

Please select one of the following materials/tools from 1 to 6 for drawing:

1. **Integrated Drawing** : wood color, pen, crayons, (A4, A3 drawing paper optional). You can freely add handicraft materials in an appropriate amount: rags, colored shredded paper, film, plastic beads, beans and environmentally friendly materials. Tools: paste, glue, small broom, scissors.
2. **Watercolor**: watercolor paint, watercolor box, brush, (A4, A3 and A2 watercolor paper optional).
3. **Sketching**: black pencil, charcoal, charcoal strip, charcoal, eraser, (A4, A3, A2 drawing paper optional).
4. **Oil painting**: oil paints, drawing boards, oil brushes, (A4, A3, A2 canvases optional).
5. **Acrylic Painting**: Acrylic paint, drawing board, canvas, Acrylic brush, (A4, A3, A2 paper optional).
6. **Comic** : Marker (pen), pencil, wood color, Acrylic, (A2, A3, A4 paper optional).
7. **Small fans and hair dryers can be used to dry paintings.**
8. **You can use pencil and eraser to draw sketches.**

Exam Assessment Format

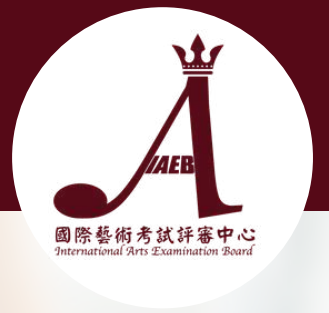

Use smartphones, laptops, cameras, video recorders and other equipment to record videos, and must follow the following video specifications.

Video specifications

Video resolution	720p (1280 x 720) or (720 x 1280) MP4,
video format	WMV, MOV or MPG YouTube, Google Drive,
Submit link method	Dropbox

Exam Assessment Time and Venue



Examination Timetable: (Yearly)

1st January - 30th April	1st May - 30th August	1st September - 30th December
Registration + Payment period + File upload date + exam month: January 1st, 12:00 AM - April 30th, 12:00 am	Registration + Payment period + File upload date + exam month: May 1st, 12:00 am - August 30th, 12:00 am	Registration + Payment period + File upload date + exam month: September 1st, 12:00 am - December 30th, 12:00 am
Result + Certificate release month: May (30 working days)	Result + Certificate release month: September (30 working days)	Result + Certificate release month: January (30 working days)

Exam Venue:

Any location, be it home, school, music room, painting room, community hall, etc.

The recording location cannot be an open venue, such as a shopping mall or street.

Examination fees are divided into individual and group



Level

Price (HKD)

Elementary

Individual | Group

Foundation	\$850 \$725
Level 1	\$950 \$800
Level 2	\$1,050 \$900
Level 3	\$1,150 \$1,000

Intermediate

Level 1	\$1,200 \$1,050
Level 2	\$1,300 \$1,100
Level 3	\$1,400 \$1,200

Higher

Level 1	\$1,500 \$1,300
Level 2	\$1,600 \$1,400
Level 3	\$1,800 \$1,500

Group Application Benefits

Schools, academic institutions, etc. are welcome to register students as a group. The maximum number of group registrations is 30 people.

Please refer to the attached chart and the following requirements:

1. Group registration must be done once
2. Group registration can apply for different subjects and different levels
3. The examination files submitted for group registration must include candidate information
4. Examination results will be notified and released to the registered school / academic institute / centre etc.
5. The certificate will be issued in the form of electronic certificate

Duration of each art exam



Subjects	Elementary (Maximum 90 minutes)	Intermediate (Maximum 120 minutes)	Higher (Maximum 150 minutes)
	Foundation* Level 1 Level 2 Level 3	Level 1 Level 2 Level 3	Level 1 Level 2 Level 3

* Only Integrated Drawing has a Foundation level exam.

Circumstance 1 : Get a Award

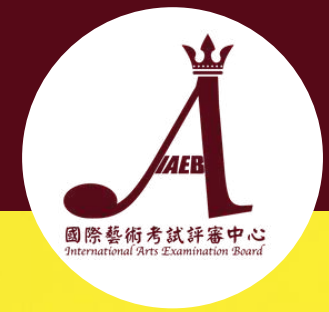

1. Candidates can take any subject and at any level within the six subjects.

2. For example: A candidate who takes the Elementary level one oil painting exam can obtain a Elementary level one oil painting certification.



***Award Sample**

Circumstance 2: Get a Certificate



1. Candidates may register for any two different subjects within the six subjects, and they must be at the same level.
2. For example:
Candidates taking the watercolor and comics exams must be at the Elementary level 2. They will receive a certification for each subject: a Elementary level 2 watercolor certification and a Elementary level 2 comics certification. They will also receive an additional certificate specifying their level as Elementary level 2 in both watercolor and comics.



*Certificate Sample

Circumstance 3: Get a Diploma Certificate



1. Candidates must complete the Level 1 to 3 Elementary level and one intermediate level exam in a subject before they can apply for one Higher level exam. (The intermediate and Higher levels must be the same level.) Progression must be gradual; skipping levels is not allowed.
2. For example:
Candidates focus on one of the six subjects in the exam: Sketching.
 1. First, candidates must complete the Elementary level 1 to Elementary level 3 sketching exams.
 2. Then, candidates can register for the intermediate level 1 sketching exam and the higher level 1 sketching exam.
 3. Upon completion, they will obtain a Level 1 sketching diploma.



***Diploma Certificate Sample**

How long does it take to get the exam results?

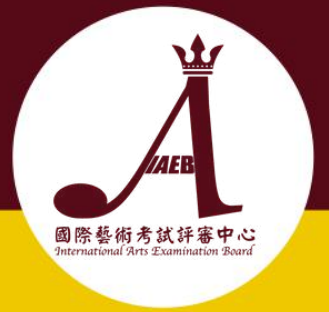

Within 30 working days

Candidate results will be announced via email within 30 working days.



How can I get the certificate?



The electronic certificate will be issued by email within **30 working days**.

However, the physical version of the diploma or certificate needs to be sent to the candidate's address via SF Express **within a month**, and the postage must be paid by the candidate.

To purchase a physical diploma or certificate, the cost is **HKD \$380**.





國際藝術考試評審中心
International Arts Examination Board

Thank You

www.iaebart.org
